

Contents

Changes to incorporate RFR and 2021 Definitions structures into FpML 4.x/5.x	3
To fpml-enum.xsd:	3
• Add a new simpleType “CalculationMethodEnum”	3
• [4.x only] Change the existing “CompoundingMethodEnum”	3
• Add a new simpleType “CsaTypeEnum”	3
• Add a new simpleType “ObservationPeriodDatesEnum”	3
• Add a new simpleType “PartyDeterminationEnum”	3
To fpml-shared.xsd:	3
• Add a new complexType “BenchmarkRate”	3
• Add a new complexType “BusinessCentersOrReference”	3
• Add a new complexType “CalculationParameters”	4
• Add a new complexType “FallbackRate”	4
• Add a new complexType “FallbackRateObservation”	4
• [Refactoring Work] Change the existing complexType “FloatingRate”	5
• [Refactoring Work] Change the existing complexType “FloatingRateCalculation”	5
• [Refactoring Work] Add a new complexType “InflationRateCalculationBase”	7
• Add a new complexType “MutuallyAgreedClearinghouse”	7
• Add a new complexType “ObservationOffset”	7
• Add a new complexType “ObservationShiftParameters”	8
• Add a new complexType “OrganizationIdentifier”	8
• Change the existing complexType “RateObservation”	8
• [4-x only] Add a new complexType “SwaptionPhysicalSettlement”	9
• [5-x only: Refactoring Work] Change the existing complexType “StubFloatingRate.”	9
○ to add a new “floatingRate.model” to group 5 existing elements for deprecation (see highlighted in the diagram below)	9
• [4-x only: Refactoring Work] Add a new complexType “StubFloatingRate”	10
○ to prevent the new “calculationParameters” components from inclusion in the Stub.	10
• [Refactoring Work] Add a new floatingRate.model	10
○ to group the following elements together	10
• [Refactoring Work] Add a new “FloatingRateCalculation.model”	11
○ to group the following elements together	11

- [4.x only Refactoring Work] Add a new "FloatingRateIndex.model"11
- Add a new "ObservationParameters.model"12
- [5.x only] Change the existing "StubFloatingRateIndex.model"12
- To fpml-ird.xsd:12**
 - Change the existing complexType "CashSettlement",12
 - to replace the optional choice of various cash settlement methods12
 - Add a new complexType "CollateralizedCashPriceMethod"14
 - [Refactoring Work] Change the existing complexType "InflationRateCalculation"14
 - to extend from the new "InflationRateCalculationBase".14
 - Add a new complexType "MidMarketValuation"17
 - Add a new complexType "MidMarketValuationMethod"17
 - Add a new complexType "PartySelector"17
 - Add a new complexType "ReplacementValue"17
 - Add a new complexType "ReplacementValueCalculationAgentDeterminationMethod"18
 - Add a new complexType "ReplacementValueFirmQuotationsMethod"18
 - Add a new complexType "ReplacementValueMethodBase"18
 - Add a new model group "CashSettlementMethods2006.model"19
 - Add a new model group "CashSettlementMethods2006and2021.model"19
 - Add a new model group "CashSettlementMethods2021.model"19
 - [4-x only]: Change complexType "Swaption"19
 - to allow an optional choice of "cashSettlement" and "physicalSettlement" of type
SwaptionPhysicalSettlement19
 - Notes:21
- To confirmation-view-examples/products/interest-rate-derivatives:21

Changes to incorporate RFR and 2021 Definitions structures into FpML 4.x/5.x

To fpml-enum.xsd:

- Add a new simpleType “CalculationMethodEnum”
- [4.x only] Change the existing “CompoundingMethodEnum”
 - to add option “SpreadExclusive” – resulting list should include Flat, None, Straight, and SpreadExclusive
- Add a new simpleType “CsaTypeEnum”
- Add a new simpleType “ObservationPeriodDatesEnum”
- Add a new simpleType “PartyDeterminationEnum”

To fpml-shared.xsd:

- Add a new complexType “BenchmarkRate”
 - See Changes to Coding Scheme types below
- Add a new complexType “BusinessCentersOrReference”

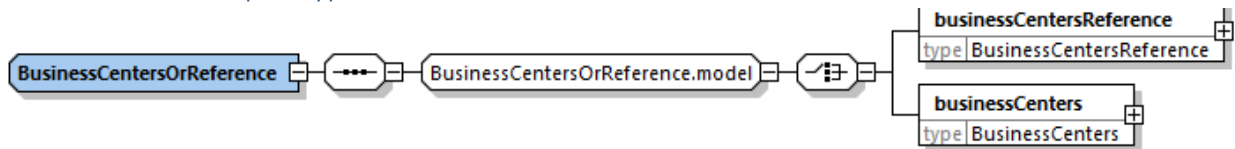

- Add a new complexType "CalculationParameters"

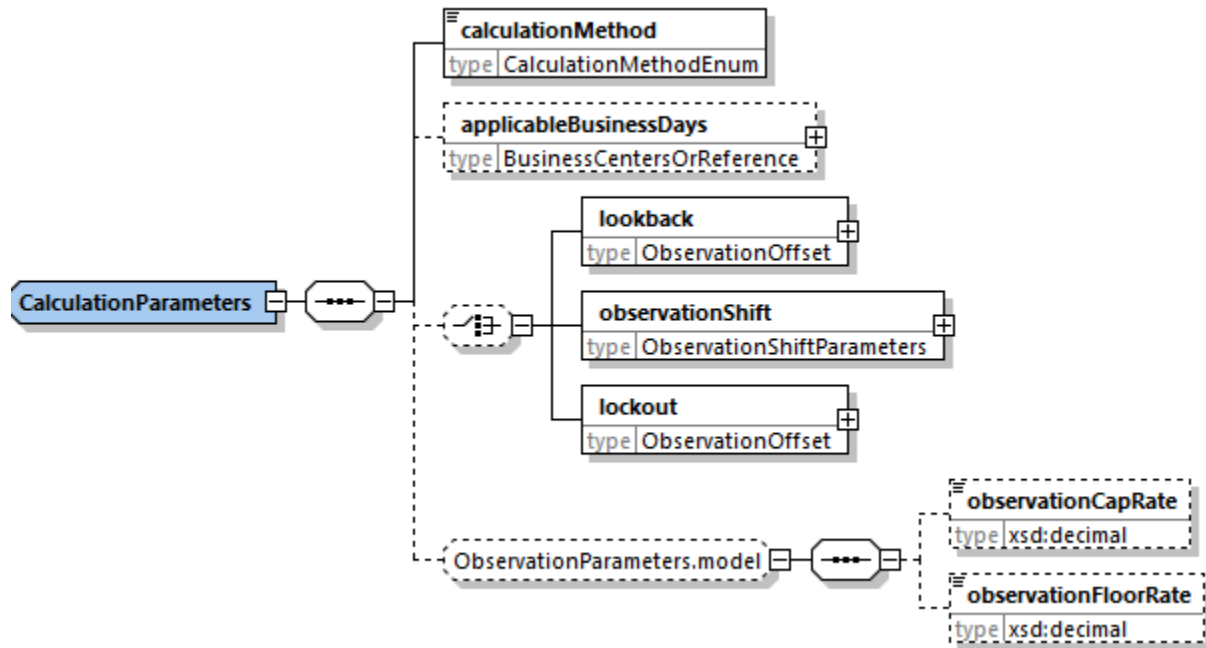

- Add a new complexType "FallbackRate"

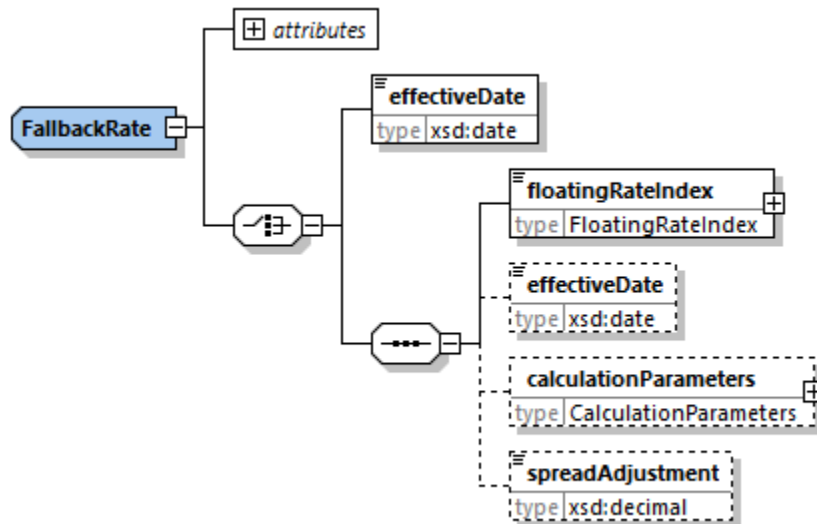

- Add a new complexType "FallbackRateObservation"

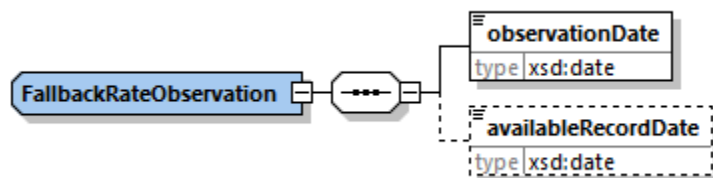

- [Refactoring Work] Change the existing complexType "FloatingRate"
 - Add a new optional element "calculationParameters" of type "CalculationParameters"
 - Add a new optional element "fallbackRate" of "FallbackRate"
 - Add a new "floatingRate.model" to group 5 existing elements together
 - See "Add a new "floatingRate.model" below."
 - Note, in 4.x floatingRateIndex and indexTenor are in 4.x – in sequence vs in 5.x – in floatingRateIndex.model – see circled in blue

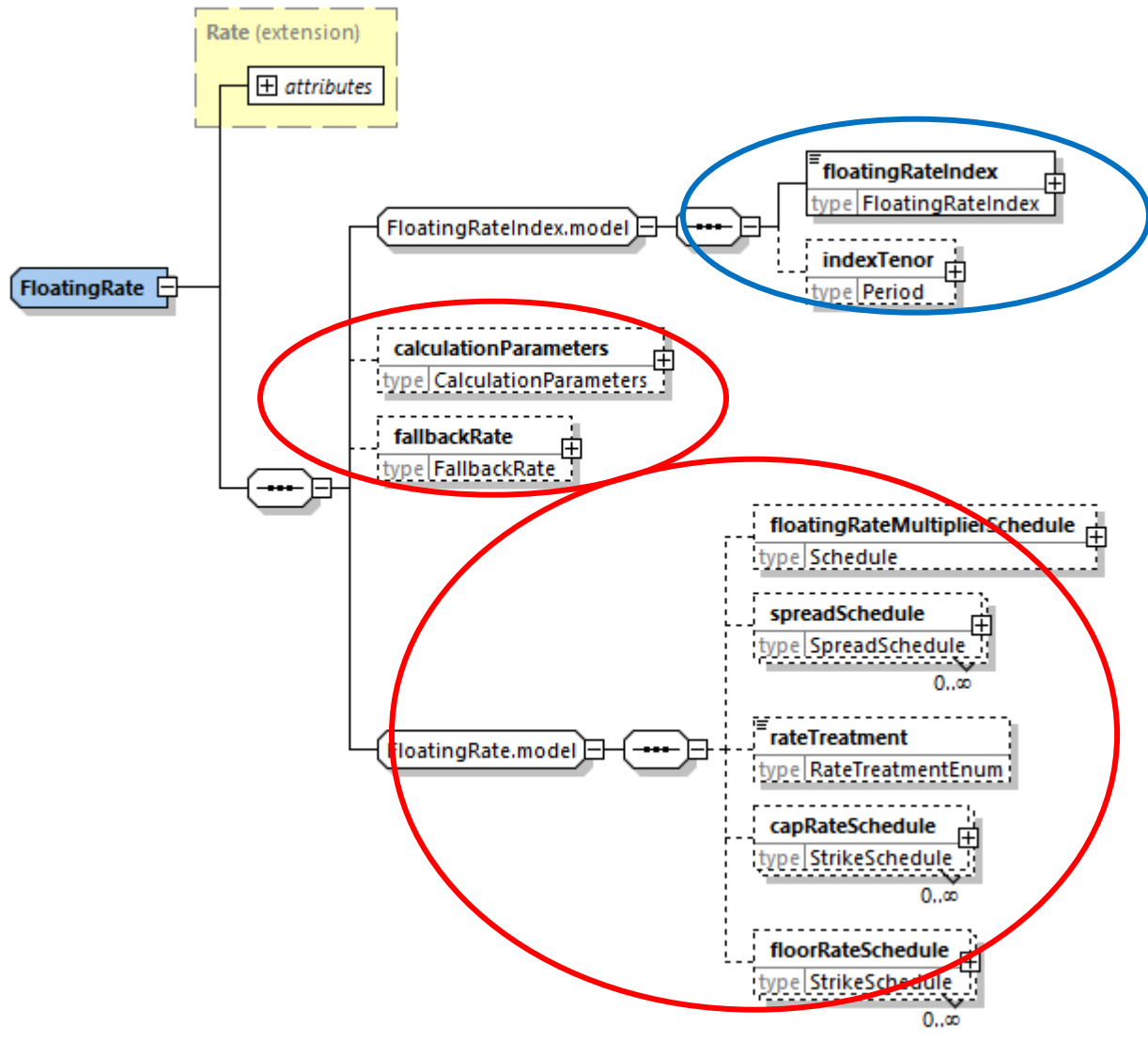

- [Refactoring Work] Change the existing complexType "FloatingRateCalculation"
 - Add a new `FloatingRateCalculation.model` to group 4 existing elements together
 - See "Added a new `FloatingRateCalculation.model`" below

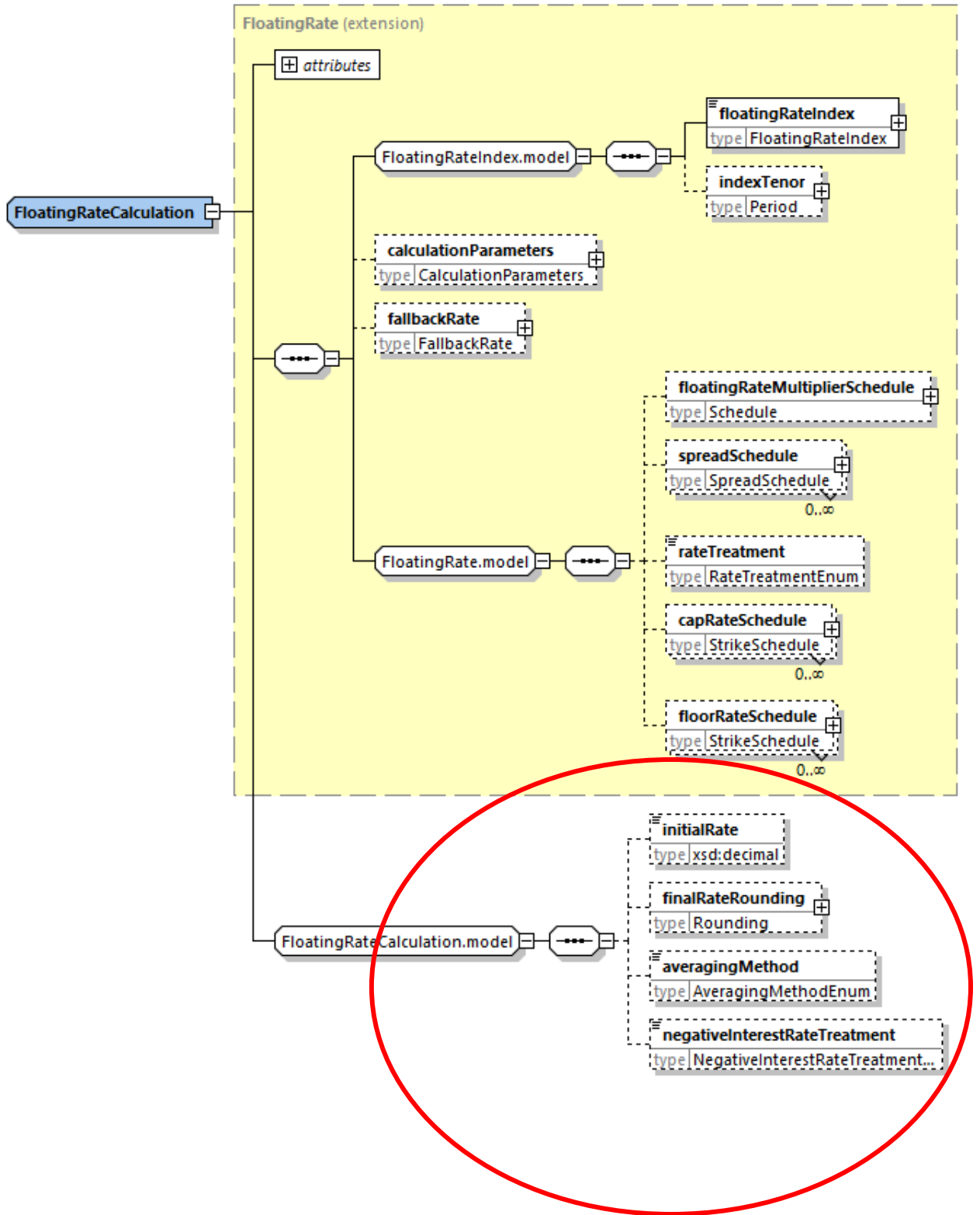

- [Refactoring Work] Add a new complexType "InflationRateCalculationBase"

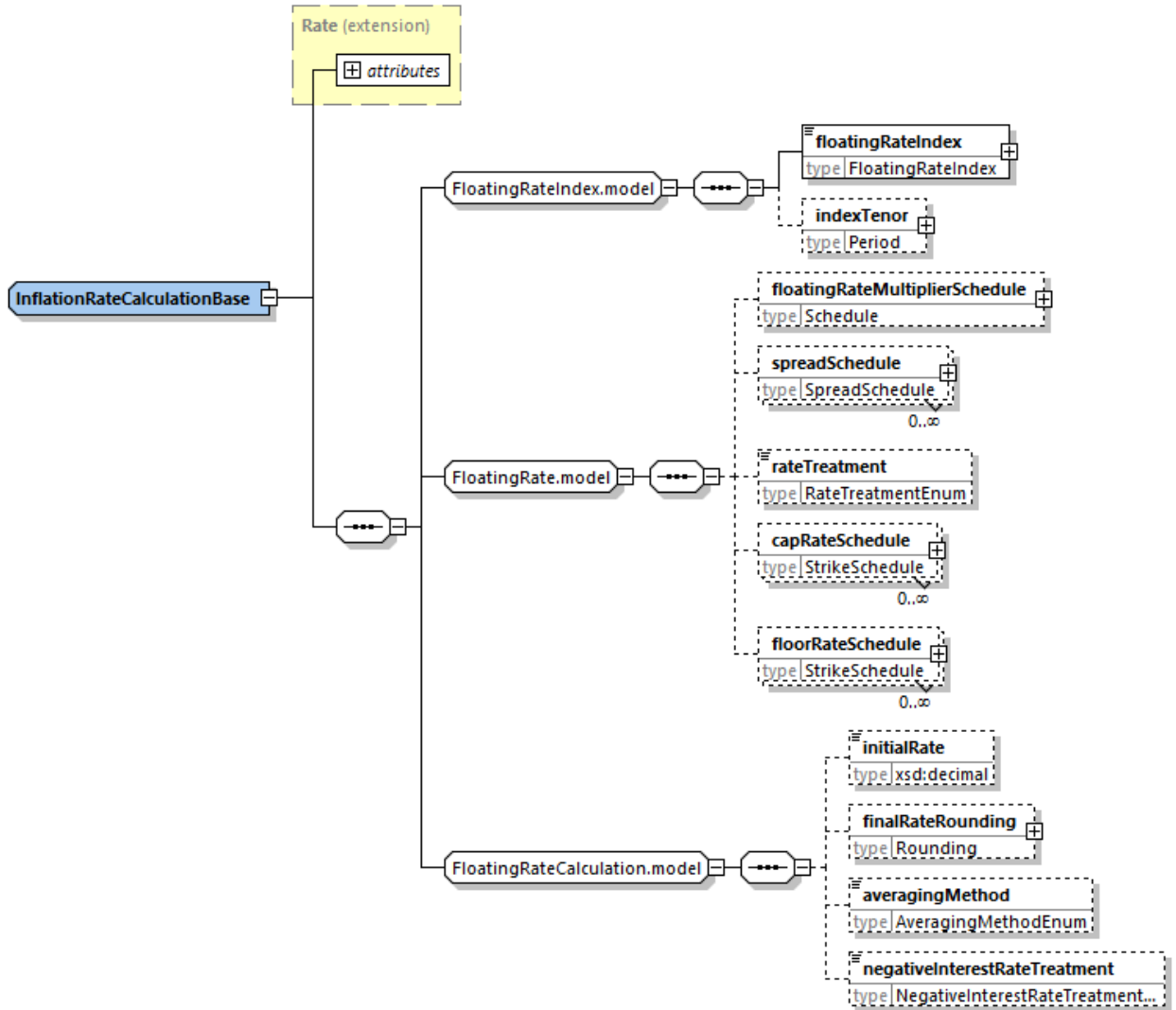

- Add a new complexType "MutuallyAgreedClearinghouse"

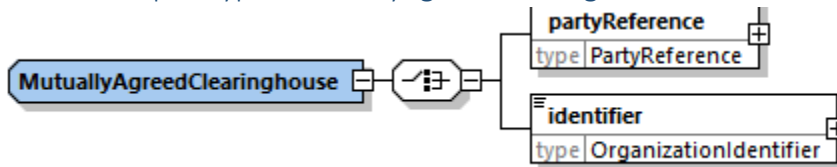

- Add a new complexType "ObservationOffset"

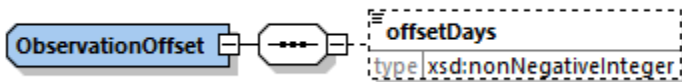

- Add a new complexType "ObservationShiftParameters"

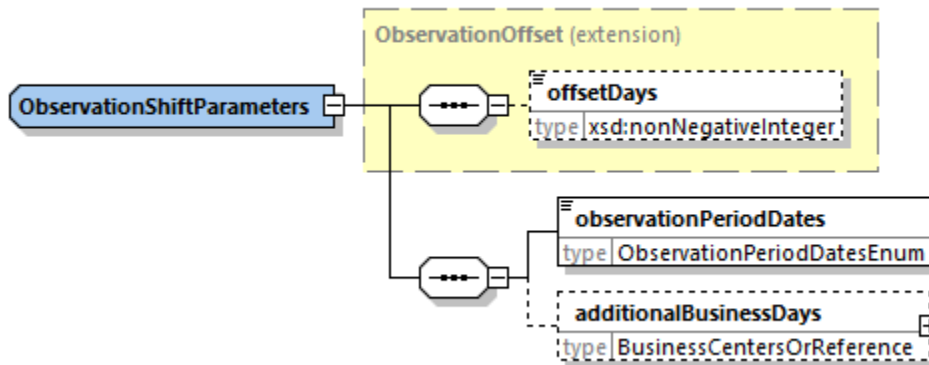

- Add a new complexType "OrganizationIdentifier"
 - See "Changes to Coding Scheme types" below
- Change the existing complexType "RateObservation"
 - to add a new element "fallback" of type "FallbackRateObservation"
 - Note, in 4.x observationWeight is mandatory element vs in 5.x, it is optional

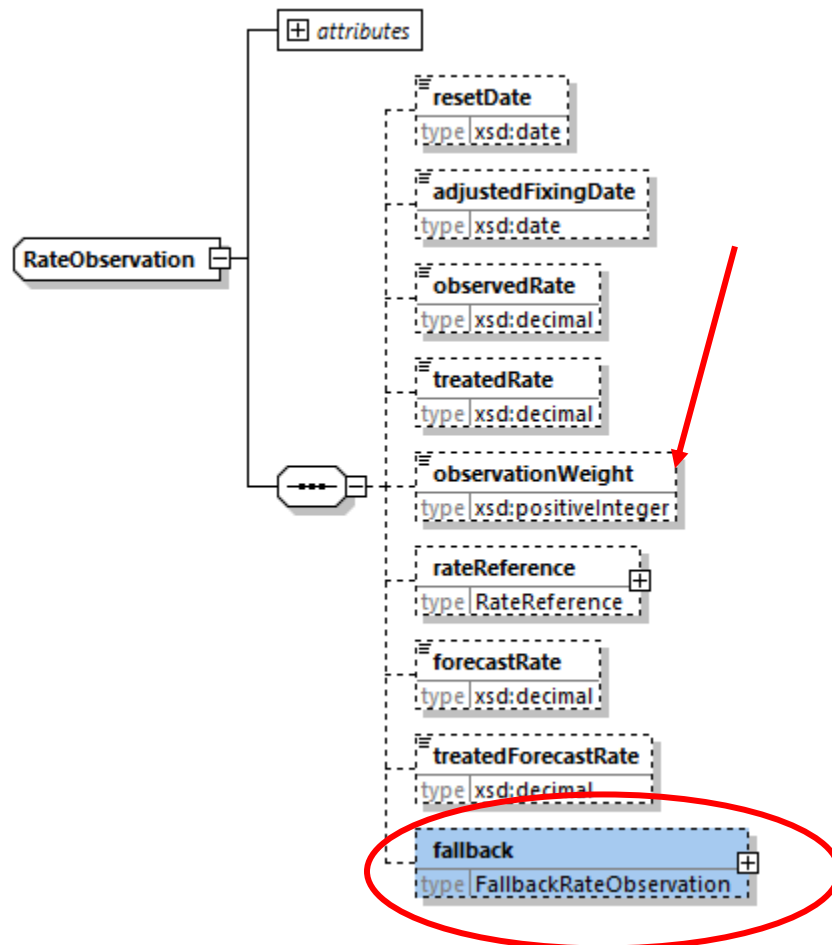

- [4-x only] Add a new complexType "SwaptionPhysicalSettlement"

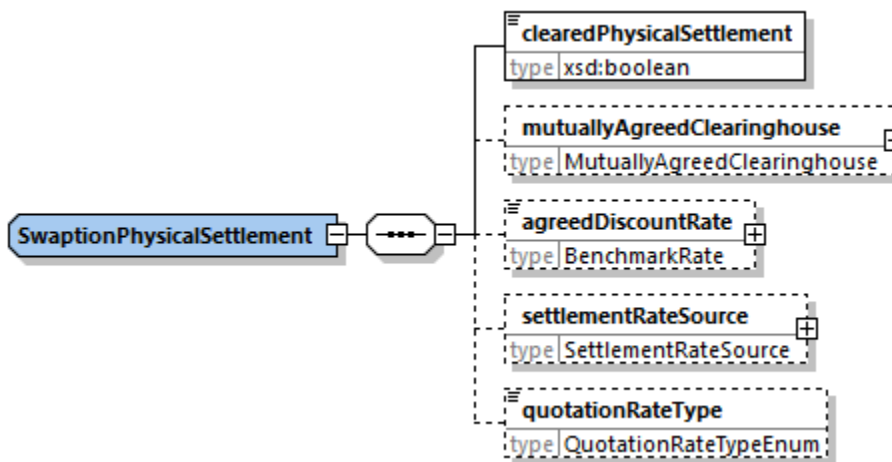

- [5-x only: Refactoring Work] Change the existing complexType "StubFloatingRate."
 - to add a new "floatingRate.model" to group 5 existing elements for deprecation (see highlighted in the diagram below). Rationale: These conditioning parameters should never be applied to the stub rate, rather to the original rate. They are retained for backward compatibility with previous versions of the standard.

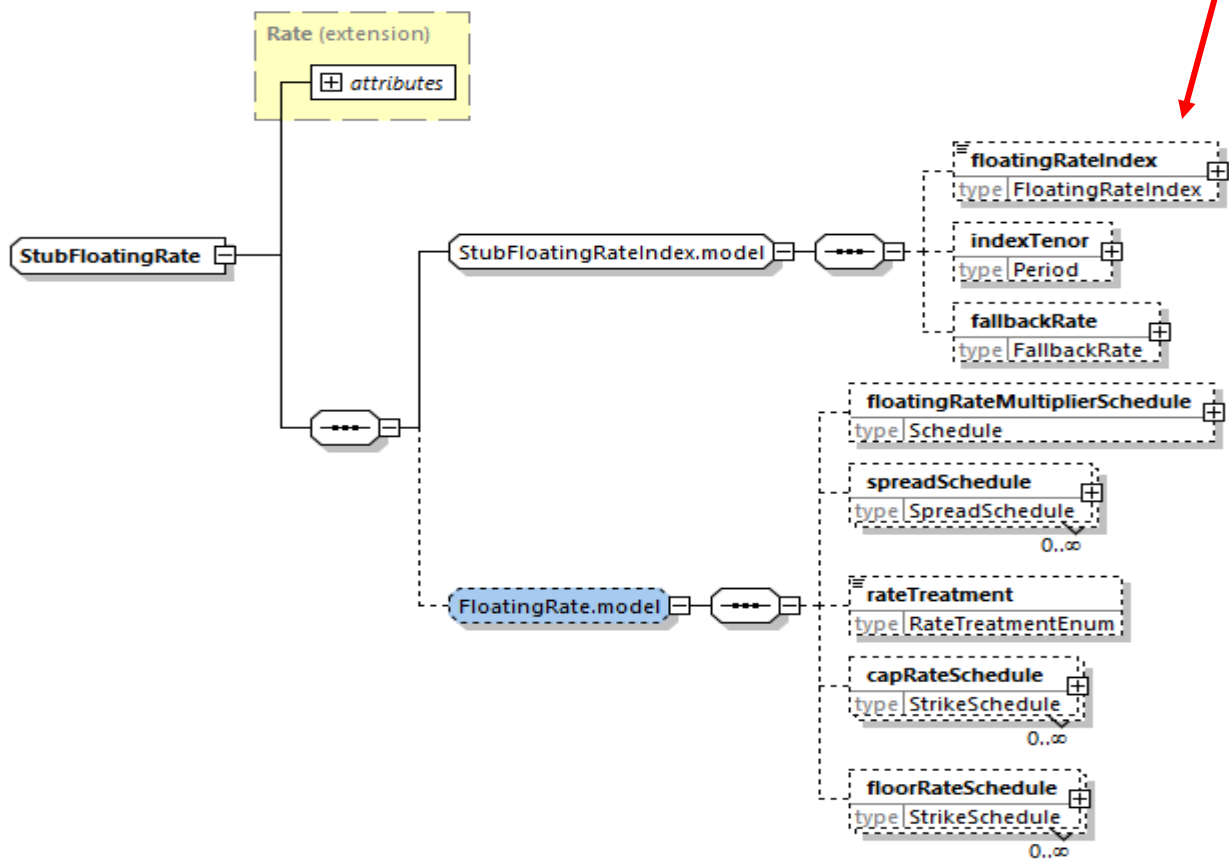

- [4-x only: Refactoring Work] Add a new complexType “StubFloatingRate”
 - to prevent the new “calculationParameters” components from inclusion in the Stub.
 - In 4.x, “StubFloatingRate”, just like in 5.x includes add a new “floatingRate.model” to group 5 existing elements for deprecation (see highlighted in the diagram below). Rationale: These conditioning parameters should never be applied to the stub rate, rather to the original rate. They are retained for backward compatibility with previous versions of the standard.
 - Note, in 4.x “StubFloatingRate” model, unlike 5.x one, the element “floatingRateIndex” is mandatory, so “FloatingRateIndex.model” is reused.

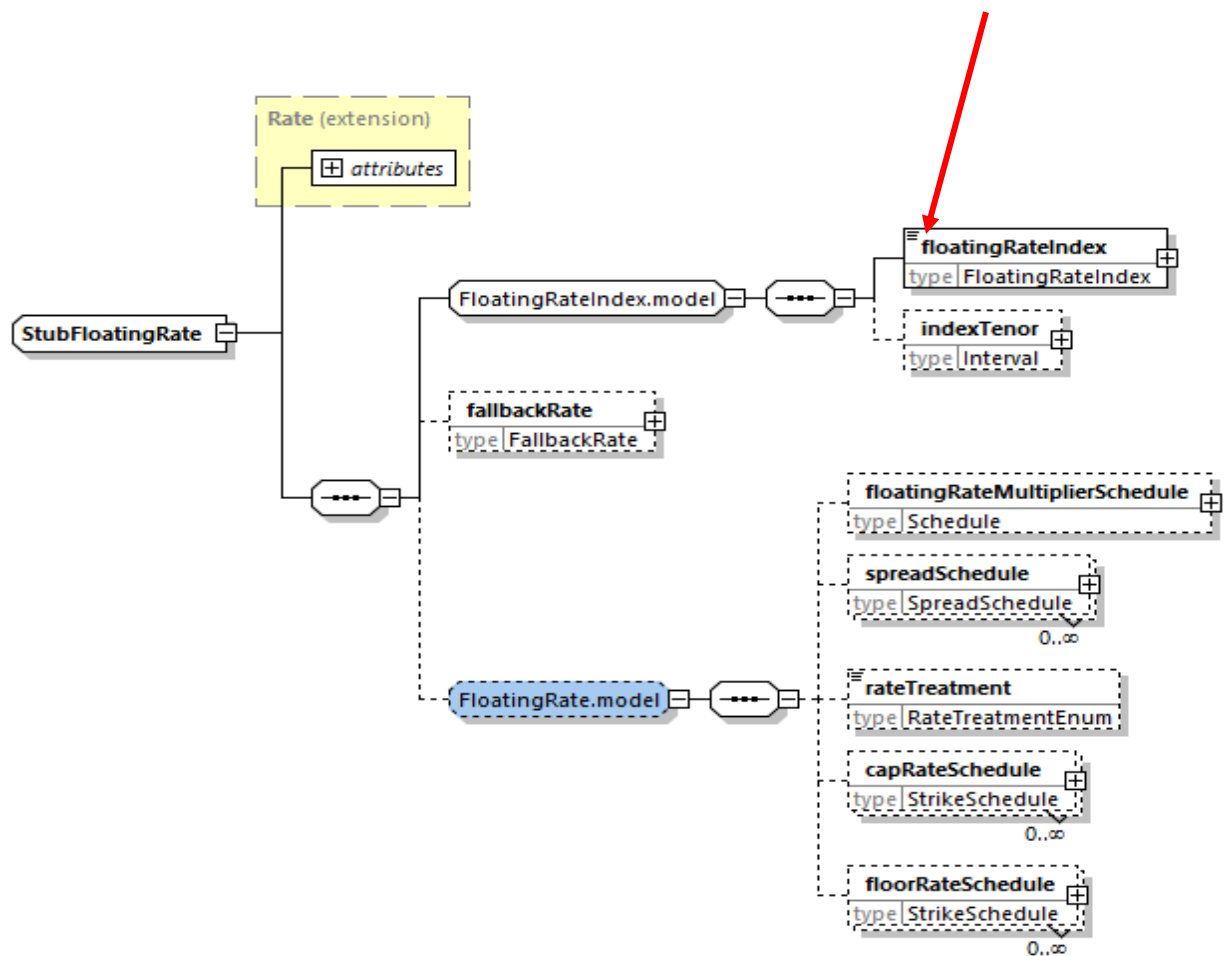

- [Refactoring Work] Add a new floatingRate.model
 - to group the following elements together: “floatingRateMultiplierSchedule”, “spreadSchedule”, “rateTreatment”, “capRateSchedule”, “floorRateSchedule” [**only in 5.x transparency view:** and capFloorStraddle].

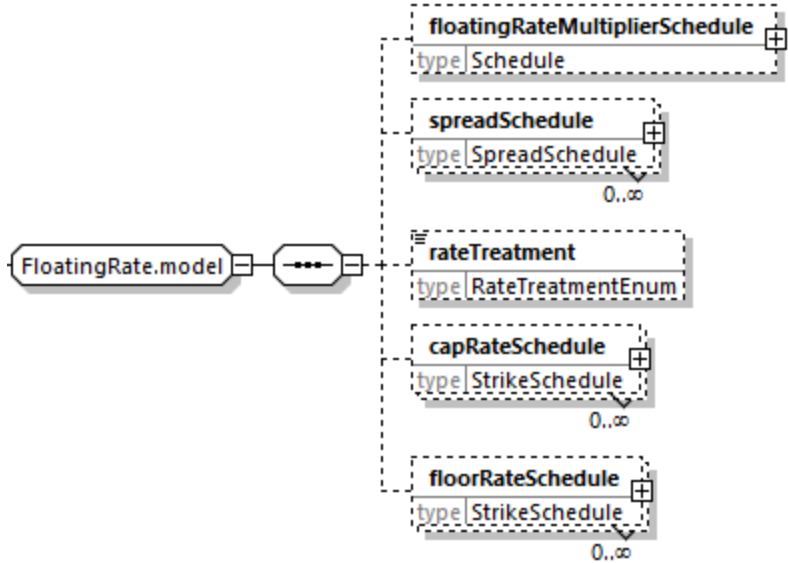

- [Refactoring Work] Add a new "FloatingRateCalculation.model"
 - to group the following elements together: `initialRate`, `finalRateRounding`, `averagingMethod`, `negativeInterestRateTreatment`.

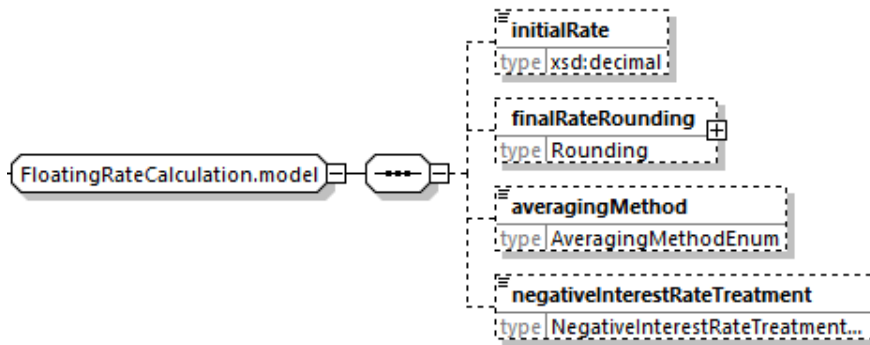

- [4.x only Refactoring Work] Add a new "FloatingRateIndex.model"
 - to group `floatingRateIndex` and `indexTenor` for reuse in different places.

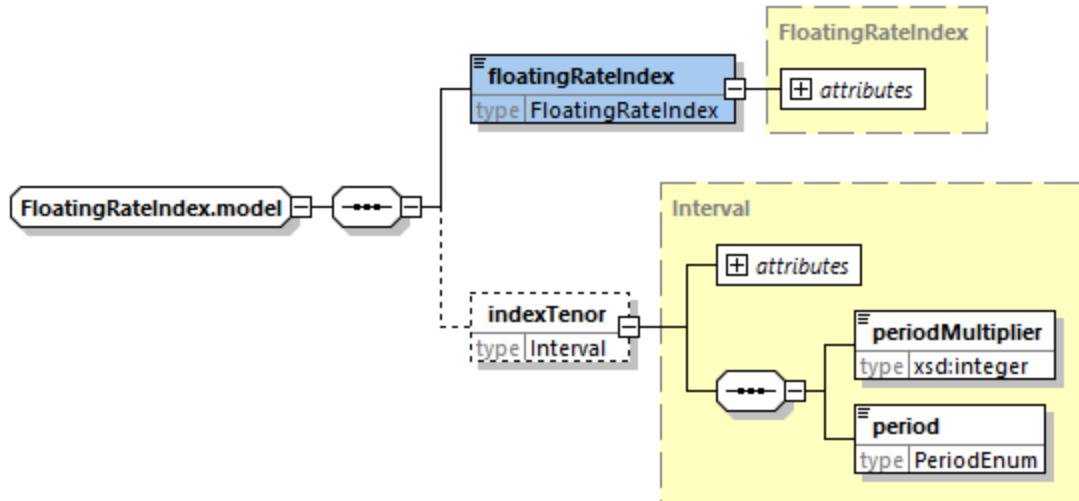

- Add a new "ObservationParameters.model"

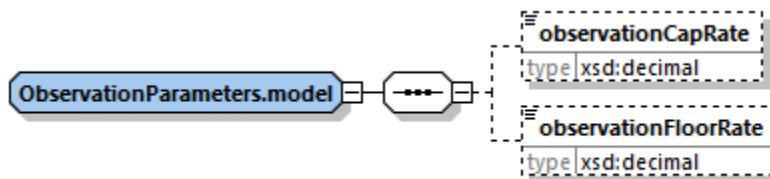

- [5.x only] Change the existing "StubFloatingRateIndex.model"
 - to add a new optional element "fallbackRate" of type "FallbackRate"

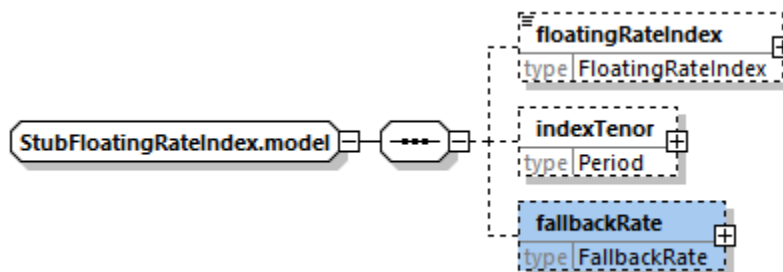

To fpml-ird.xsd:

- Change the existing complexType "CashSettlement",
 - to replace the optional choice of various cash settlement methods (cashPriceMethod, cashPriceAlternateMethod, etc.) to match the version in 5-12 (choice of 3 model groups)
 - (see diagram below)

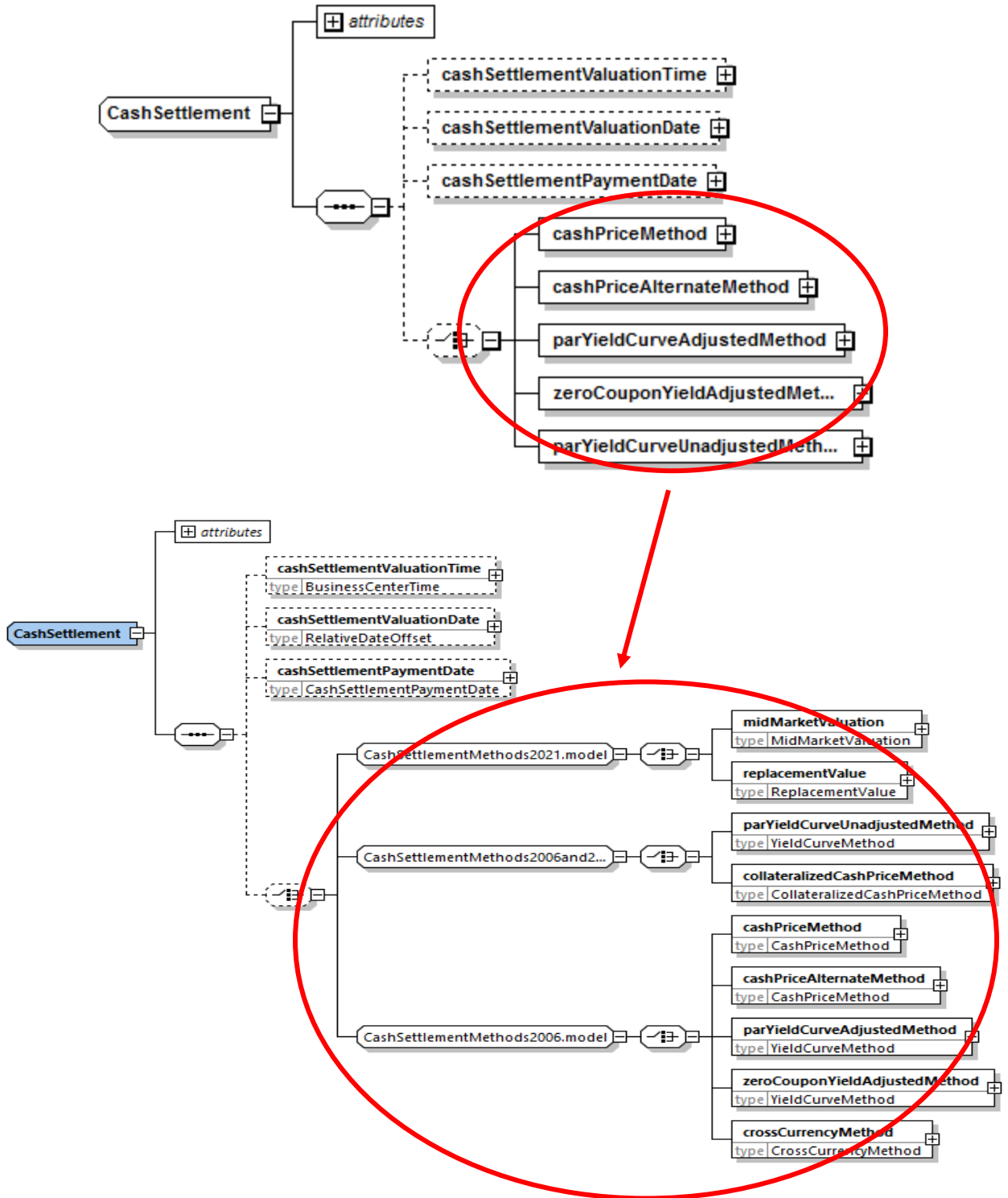

- Add a new complexType "CollateralizedCashPriceMethod"

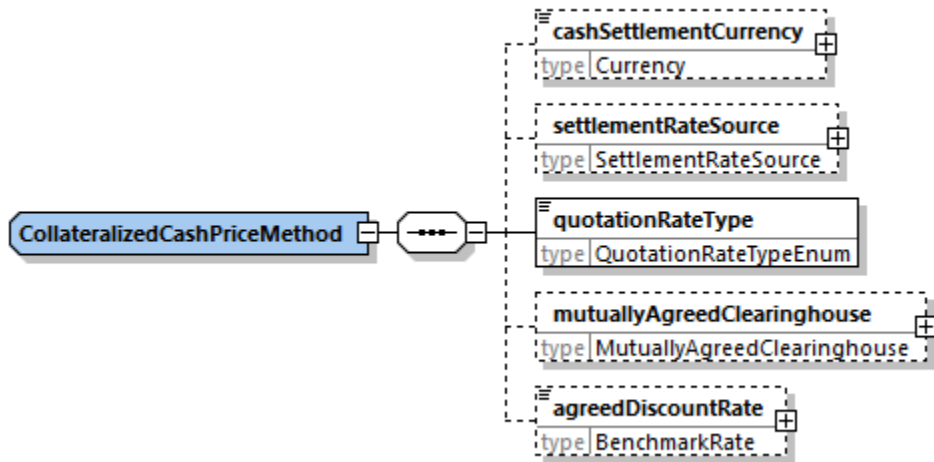

- [Refactoring Work] Change the existing complexType "InflationRateCalculation"
 - to extend from the new "InflationRateCalculationBase".
 - This change does not affect instance documents, just allows certain elements to be grouped.
 - (see 5.x diagram below)

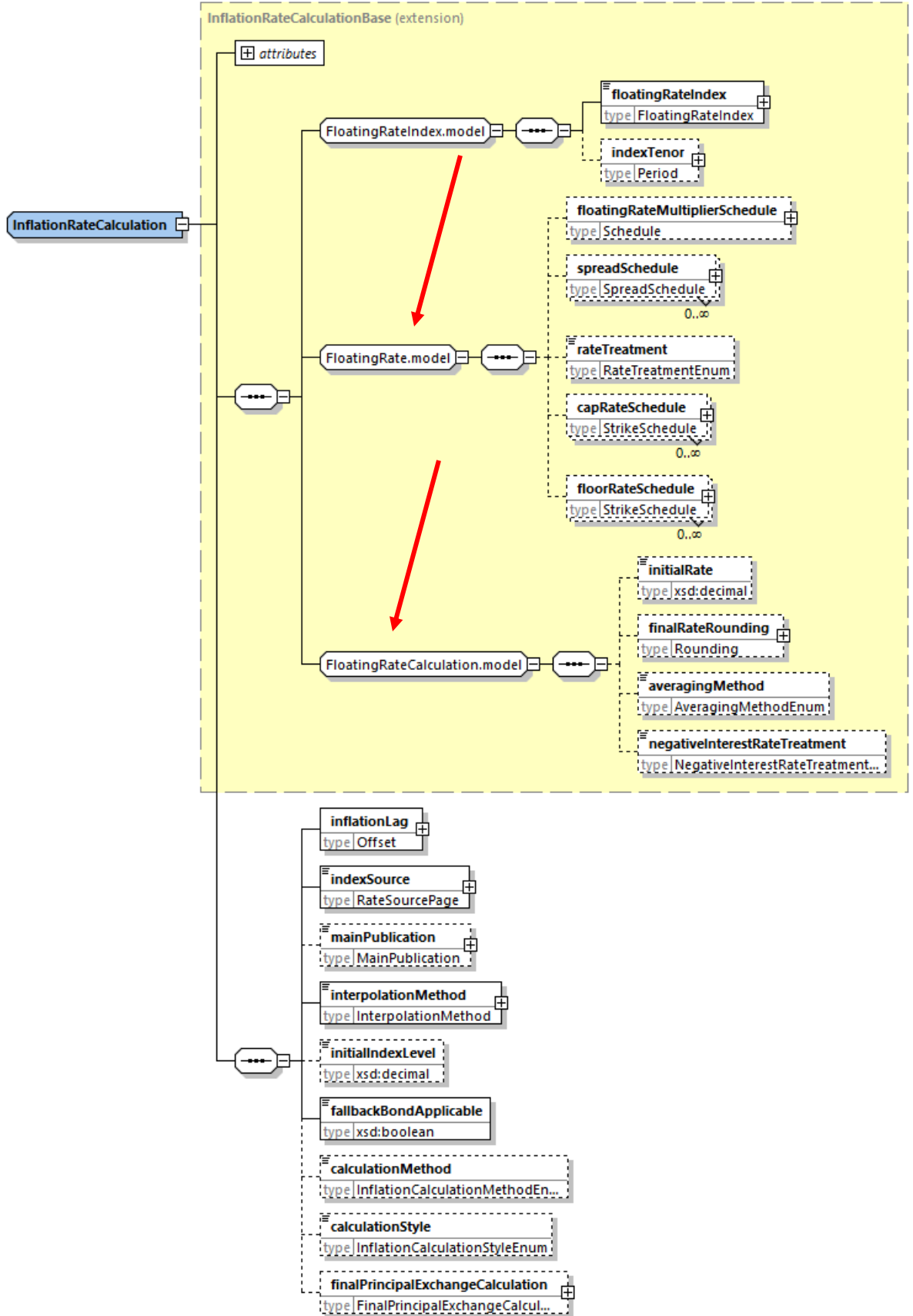

- o (see 4.x diagram below)

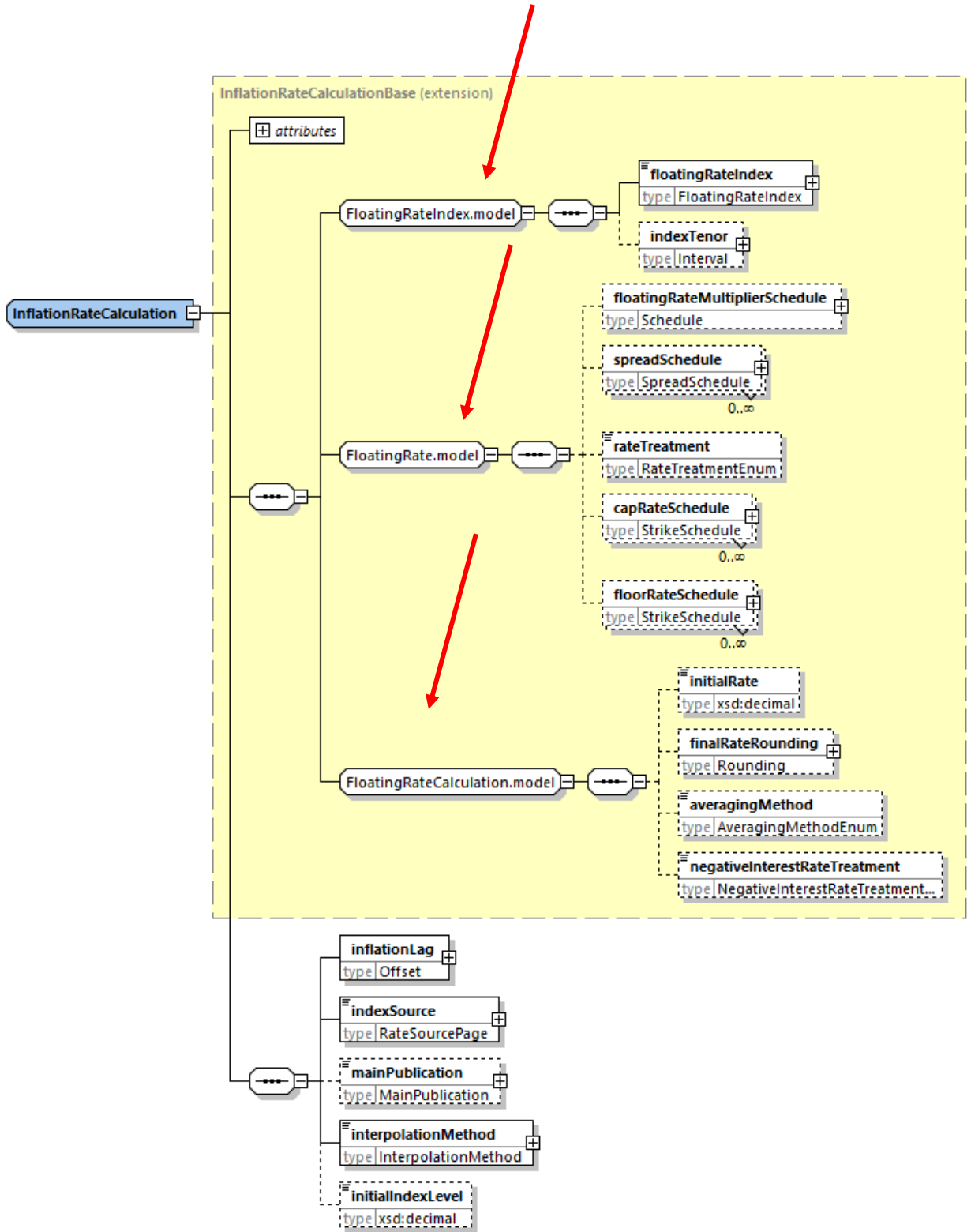

- Add a new complexType “MidMarketValuation”

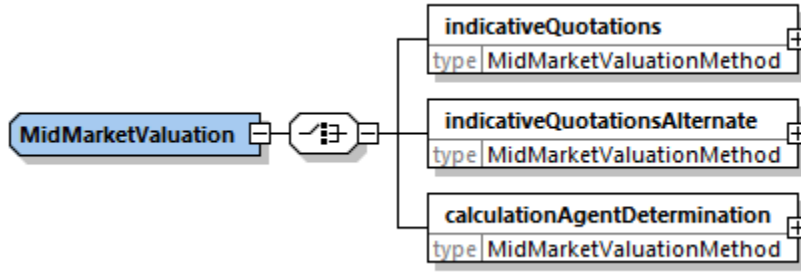

- Add a new complexType “MidMarketValuationMethod”

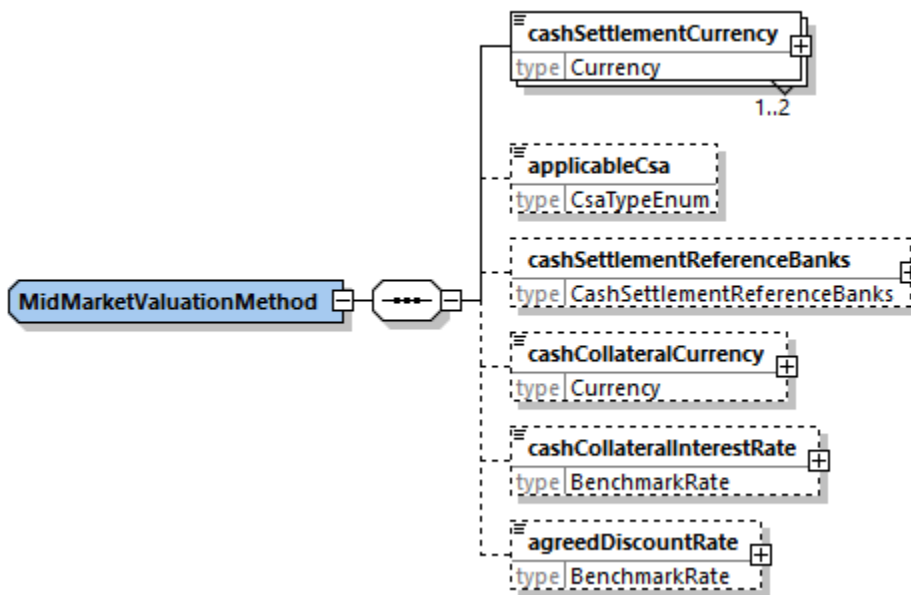

- Add a new complexType “PartySelector”

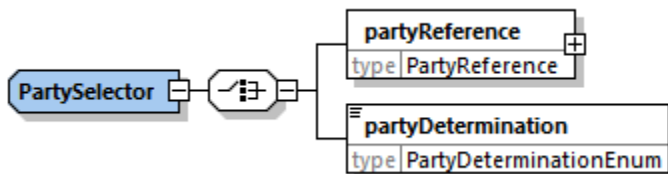

- Add a new complexType “ReplacementValue”

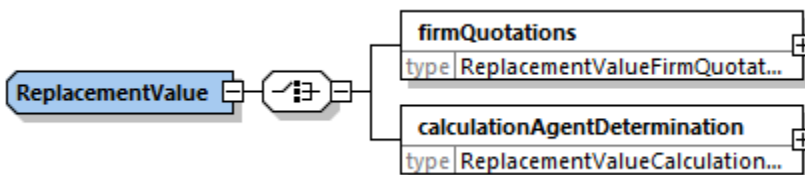

- Add a new complexType "ReplacementValueCalculationAgentDeterminationMethod"

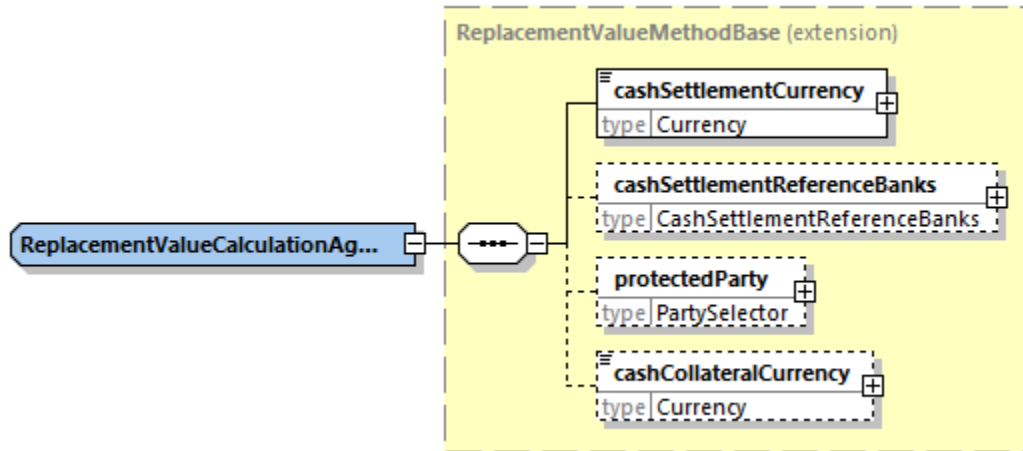

- Add a new complexType "ReplacementValueFirmQuotationsMethod"

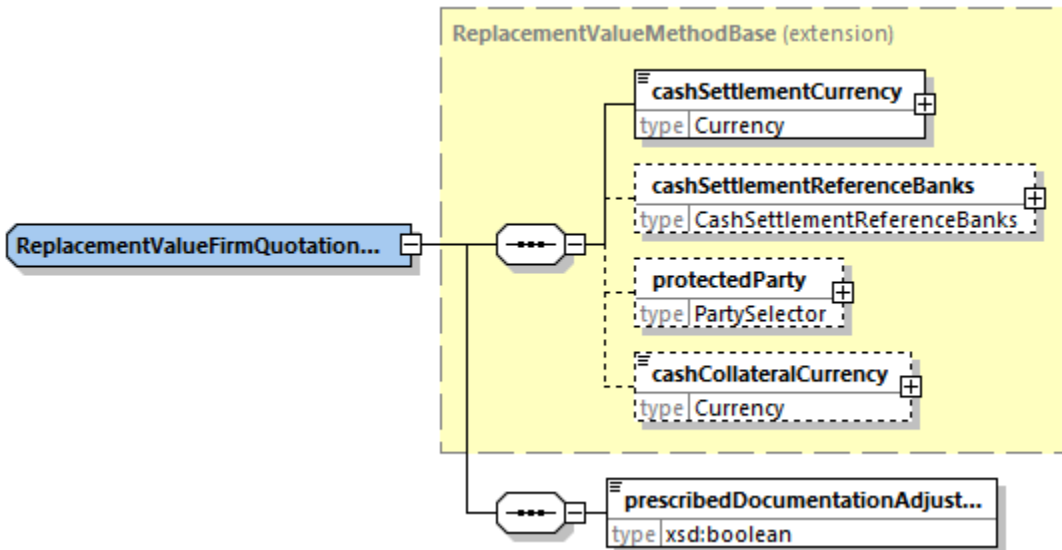

- Add a new complexType "ReplacementValueMethodBase"

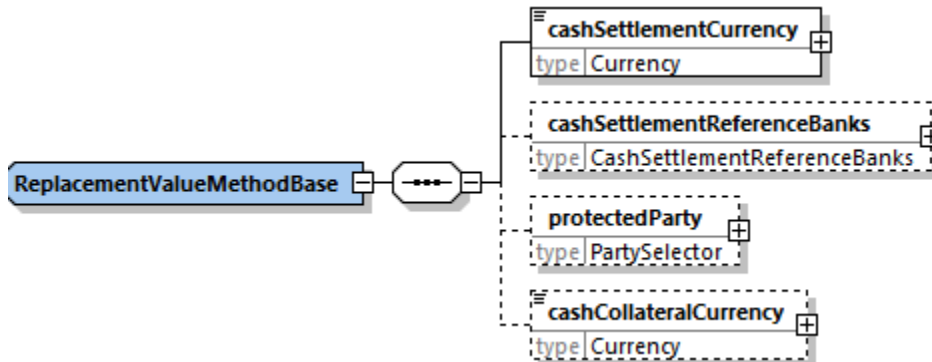

- Add a new model group “CashSettlementMethods2006.model”

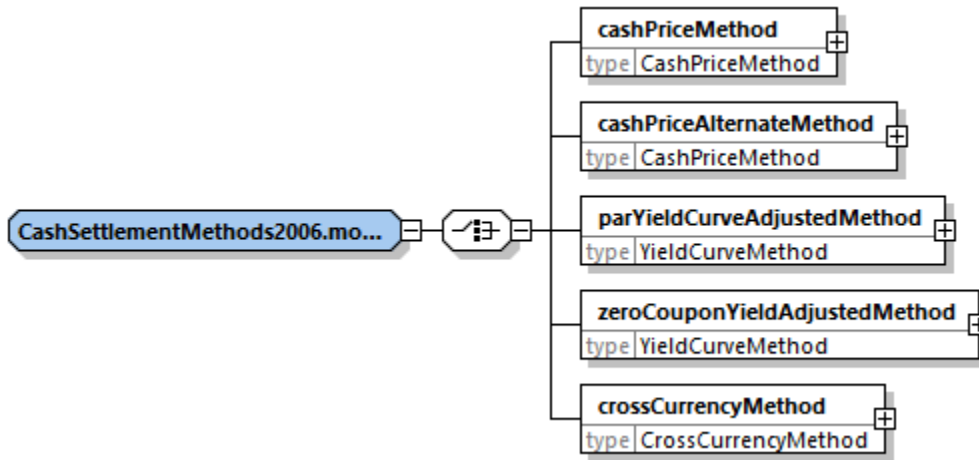

- Add a new model group “CashSettlementMethods2006and2021.model”

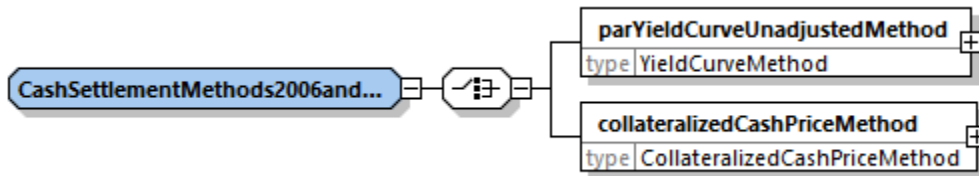

- Add a new model group “CashSettlementMethods2021.model”

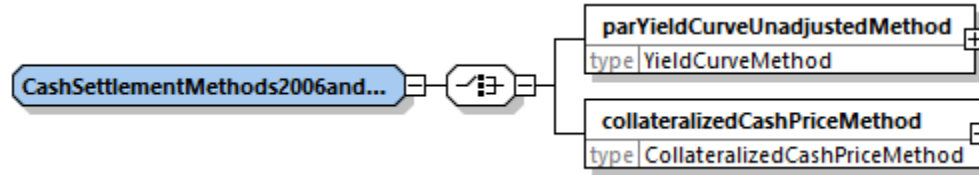

- [4-x only]: Change complexType “Swaption”
 - to allow an optional choice of “cashSettlement” and “physicalSettlement” of type SwaptionPhysicalSettlement,
 - (see diagram below)

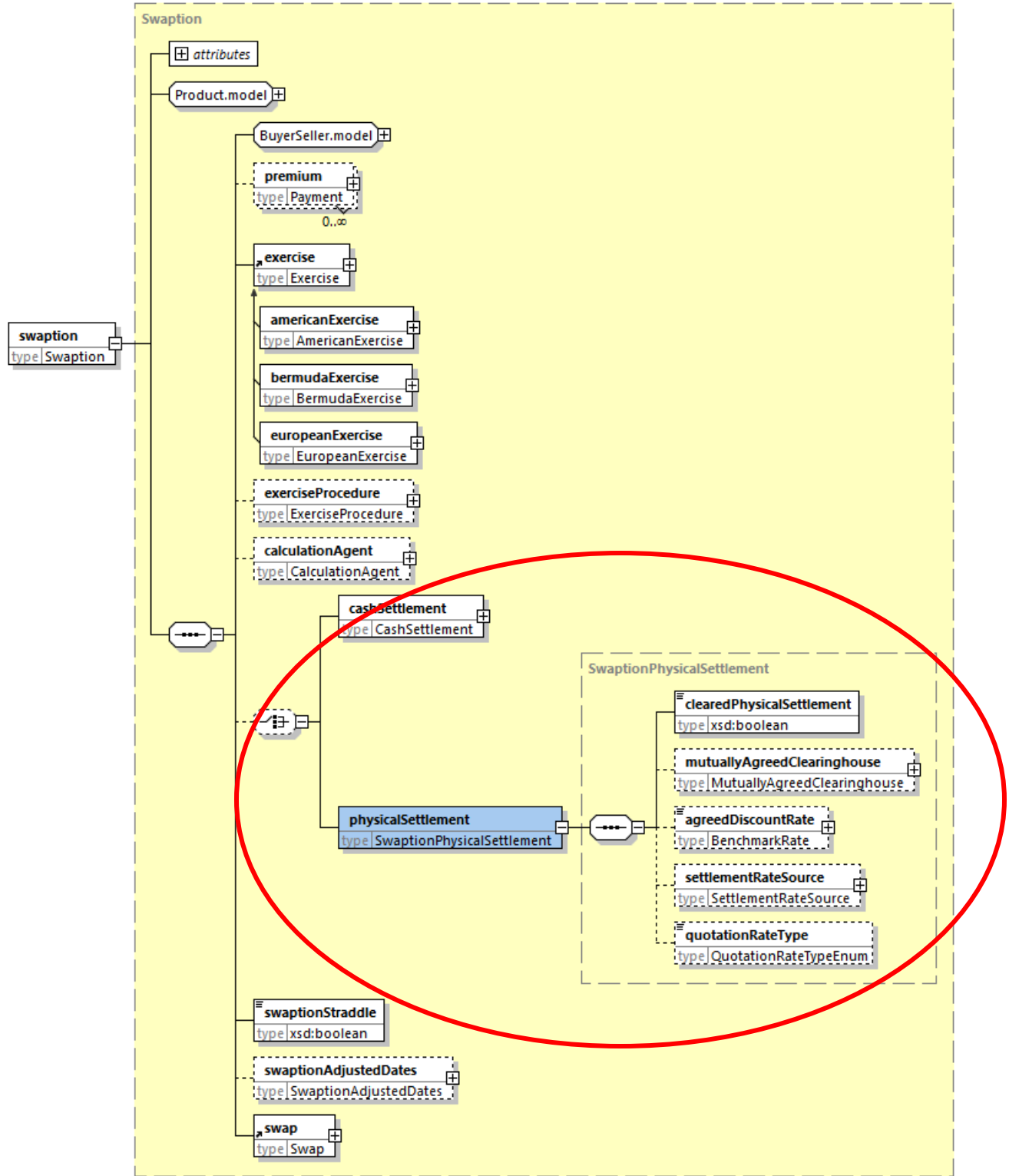

- **Notes:** Refactoring Work is to refactor the Floating Rate Calculation and the Inflation Rate Calculation models to prevent the new components from inclusion in the Inflation model, as they are not applicable.

To [confirmation-view-examples/products/interest-rate-derivatives](#):

- [4.x only] Add ird-ex38 -..xml - ird-ex57;
- [5.x only] Add ird-ex38 -..xml - ird-ex58; eqs-ex20; com-ex48; cb-option; cfindex-ex06; repo-ex09.